

## The problem: the service life of an expensive battery bank can be substantially shortened due to state of charge unbalance

One battery with a slightly higher internal leakage current in a 24 V or 48 V bank of several series/parallel connected batteries will cause under-charge of that battery and parallel connected batteries, and over-charge of the series connected batteries. Moreover, when new cells or batteries are connected in series, they should all have the same initial state of charge. Small differences will be ironed out during absorption or equalize charging, but large differences will result in damage due to excessive gassing (caused by overcharging) of the batteries with the higher initial state of charge and sulphation (caused by undercharging) of the batteries with the lower initial state of charge.

## The Solution: battery balancing

The Battery Balancer equalizes the state of charge of two series connected 12 V batteries, or of several parallel strings of series connected batteries.

When the charge voltage of a 24 V battery system increases to more than 27,3 V, the Battery Balancer will turn on and compare the voltage over the two series connected batteries. The Battery Balancer will draw a current of up to 0,7 A from the battery (or parallel connected batteries) with the highest voltage. The resulting charge current differential will ensure that all batteries will converge to the same state of charge.

If needed, several balancers can be paralleled.

A 48 V battery bank can be balanced with three Battery Balancers.

## LED indicators

**Green:** on (battery voltage > 27,3 V)

**Orange:** lower battery leg active (deviation > 0,1 V)

**Orange:** upper battery leg active (deviation > 0,1 V)

**Red:** alarm (deviation > 0,2 V). Remains on until the deviation has reduced to less than 0,14 V, or until system voltage drops to less than 26,6 V.

## Alarm relay

Normally open. Closes when the red LED switches on, and opens when the red LED switches off.

## Alarm reset

Two terminals are available to connect a push button. Interconnecting the two terminals resets the relay.

The reset condition will remain active until the alarm is over. Thereafter the relay will close again when a new alarm occurs.

## Even more insight and control with the midpoint monitoring function of the BMV-702 battery monitor

The BMV-702 measures the midpoint of a string of cells or batteries. It displays the deviation from the ideal midpoint in volts or percent. Separate deviation percentages can be set to trigger a visual/audible alarm and to close a potential free relay contact for remote alarm purposes.

Please see the manual of the BMV-702 for more information about battery balancing.

## Learn more about batteries and battery charging

To learn more about batteries and charging batteries, please refer to our book 'Energy Unlimited' (available free of charge from Victron Energy and downloadable from [www.victronenergy.com](http://www.victronenergy.com)).

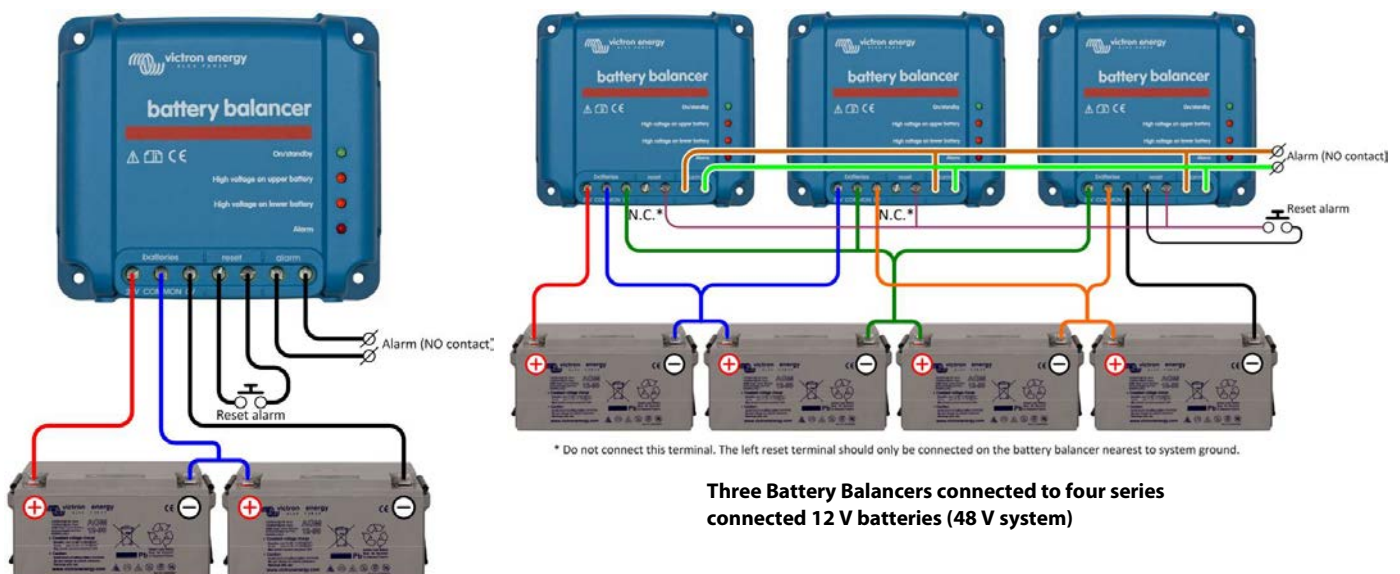

**Battery Balancer connected to two series connected 12 V batteries (24 V system)**

**Three Battery Balancers connected to four series connected 12 V batteries (48 V system)**

Victron Battery Balancer	
Input voltage range	Up to 18 V per battery, 36 V total
Turn on level	27,3 V +/- 1%
Turn off level	26,6V +/- 1%
Current draw when off	0,7 mA
Midpoint deviation to start balancing	50 mV
Maximum balancing current	0,7 A (when deviation > 100 mV)
Alarm trigger level	200 mV
Alarm reset level	140 mV
Alarm relay	60 V / 1 A normally open
Alarm relay reset	Two terminals to connect a push button
Over temperature protection	yes
Operating temperature	-30 t0 +50 °C
Humidity (non condensing)	95%
ENCLOSURE	
Colour	Blue (RAL 5012)
Connection terminals	Screw terminals 6 mm <sup>2</sup> / AWG10
Protection category	IP22
Weight	0,4 kg
Dimensions (h x w x d)	100 x 113 x 47 mm
STANDARDS	
Safety	EN 60950
Emission	EN 61000-6-3, EN 55014-1
Immunity	EN 61000-6-2, EN61000-6-1, EN 55014-2
Automotive Directive	EN 50498

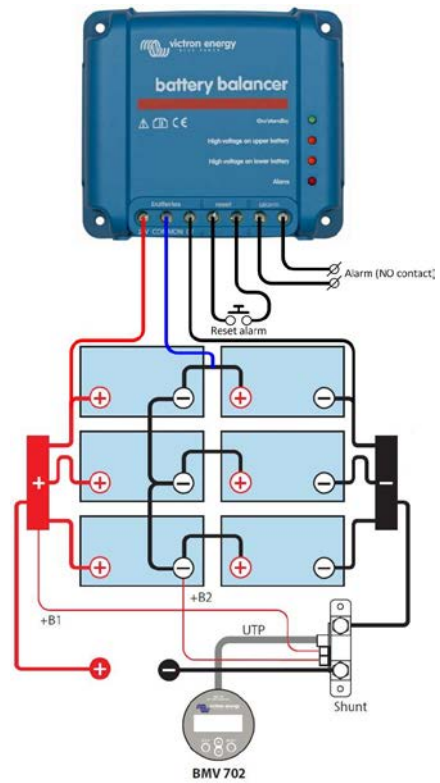

**Battery Balancer connected to six series-parallel connected 12 V batteries (24 V system)**

- ### Installation
- The battery balancer(s) must be installed on a well-ventilated vertical surface close to the batteries (but, due to possible corrosive gasses, not above the batteries!)
  - In case of series-parallel connection, the midpoint interconnecting cables must be sized to at least carry the current that arises when one battery becomes open-circuited.**
    - In case of 2 parallel strings: cross section 50% of the series interconnecting cables.
    - In case of 3 parallel strings: cross section 33% of the series interconnecting cables, etc.
  - If required: first wire the alarm contact and the alarm reset.
  - Use at least 0,75 mm<sup>2</sup> to wire the negative, positive and midpoint connections (in this order).
  - The balancer is operational.
 

When the voltage over a string of two batteries is less than 26,6 V the balancer switches to standby and all LEDs will be off.

When the voltage over a string of two batteries increases to more than 27,3 V (during charging) the green LED will turn on, indicating that the balancer is on.

When on, a voltage deviation of more than 50 mV will start the balancing process and at 100 mV one of the two orange LEDs will turn on. A deviation of more than 200 mV will trigger the alarm relay.

#### What to do in case of an alarm during charging

In case of a new battery bank the alarm is probably due to differences in initial state-of-charge. If the difference between the lowest and highest battery voltage reading is more than 0,9 V: stop charging and charge the individual batteries or cells separately first, or reduce charge current substantially and allow the batteries to equalize over time.

If the problem persists after several charge-discharge cycles:

- In case of series-parallel connection disconnect the midpoint parallel connection wiring and measure the individual midpoint voltages during absorption charge to isolate batteries or cells which need additional charging, or:
- Charge and then test all batteries or cells individually or:
- Connect two or more battery balancers in parallel (on average one balancer will take care of up to three parallel 200 Ah strings).

In case of an older battery bank which has performed well in the past, the problem may be due to:

- Systematic under charge: more frequent charging needed (VRLA batteries), or equalization charge needed (flooded deep cycle flat plate or OPzS batteries). Better and regular charging will solve the problem.
- One or more faulty cells: replace all batteries.

\* Do not connect this terminal. The left reset terminal should only be connected on the battery balancer nearest to system ground.

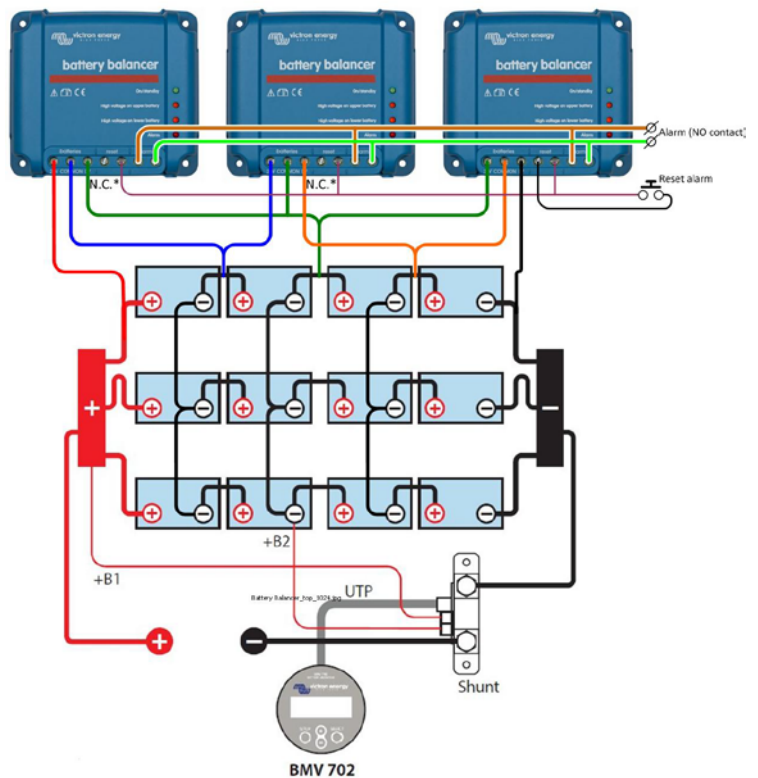

**Three Battery Balancers connected to 12 series-parallel connected 12 V batteries (48 V system)**