

MOTORCYCLE BATTERY

MHP
OWER

AGM

YTX7A-BS [12V7Ah] 110A [EN]

Specifications

Model NO.	YTX7A-BS	
Nominal Voltage	12V	
Rated Capacity (10 hours rate)	7.0Ah	
Dimensions	Length	151mm (5.94 inches)
	Width	87mm (3.42 inches)
	Height	95mm (3.74 inches)
	Total Height	95mm (3.74 inches)
Approx. Weight	2.43kg (5.35 Lbs)	
Charge Current (A)	0.7 A (14.4V constant voltage charge)	



Dimensions

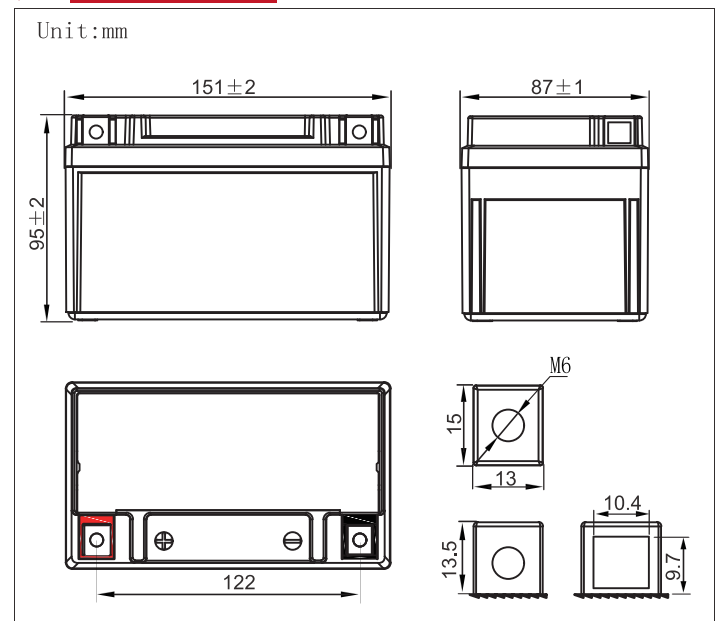

Characteristics

Capacity 25°C (77°F)	10 hours rate (0.7A to 10.5V)	7.0Ah
	5 hours rate (1.19A to 10.2V)	5.95Ah
	1C (7.0A to 9.60V)	3.15Ah
	3C (21A to 9.60V)	2.45Ah
Cranking Amperes (by Midtronic Tester)	210A	
Cold Cranking Amperes (-18°C SAE Standard)	105A	
Cold Cranking Amperes (-18°C EN Standard)	110A	
Internal Resistance (at 1KHz)	Approx. 12.5mΩ	
Operating Temperature Range	Charge	0°C (32°F) to 40°C (104°F)
	Discharge	-30°C (-22°F) to 50°C (122°F)
	Storage	-15°C (5°F) to 40°C (104°F)
Life Expectancy (Cycle Use)	60% depth of discharge 250 cycles	
	30% depth of discharge 400 cycles	
Charge Retention (self-discharge life) at 20°C (68°F)	1 month	97%
	3 month	90%
	6 month	80%
Warranty	1 year	
Case Material	ABS	

Discharge Time VS. Discharge Current (25°C)

