

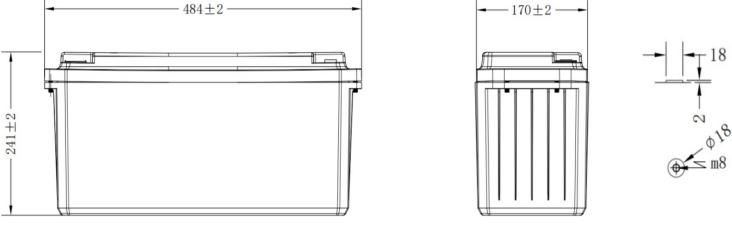

# DIGITAL SCREEN INTELLIGENT STORAGE LITHIUM BATTERY

**MODEL: PN MS150-12(L)**

**NO:**

Container Color		PANTONE		Plane Chart:	
		3516C			
		Black C			
		Terminal type	LC4		
		120 A	BMS		
		20241109	Time		
					
Function	(YES) Digital Display	(NO) Bluetooth	Product Size: 484*170*241mm		

**Parameter Chart:**

Rated Voltage	12.8	V
Rated Capacity(25°C)	150	Ah
Series & Parallels	4 ~ 1	S/P
Voltage Range	10 ~ 14.6	V
Rated Energy	1920	Wh
Maximum Discharge Current	120	A
Maximum Charge Current	120	A
Discharge cut-off voltage	≥ 10	V
Charge voltage	14.6	V
Cycle life(@25°C ,100%DOD )	≥ 3000	Cycle
Float Voltage	13.6 ~ 13.8	V
Operating humidity	60 ± 25%	R.H.
Certified	CE/UN38.3	
Communication	/	
Total Weight	Approx. 14.30 ± 0.50	Kg
Operating temperature	Charging 0 ~ 45°C Discharging -20 ~ 55°C	

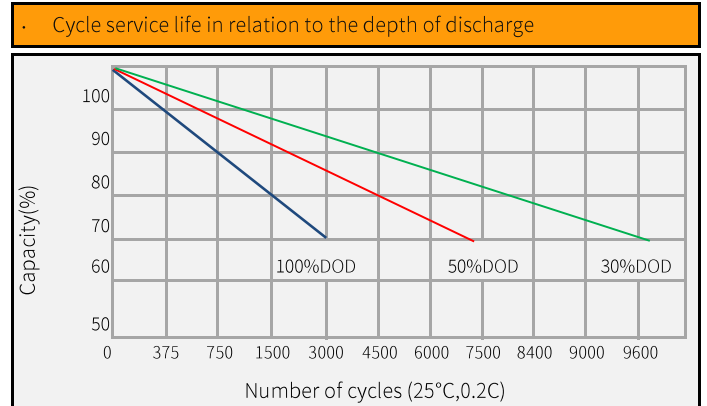
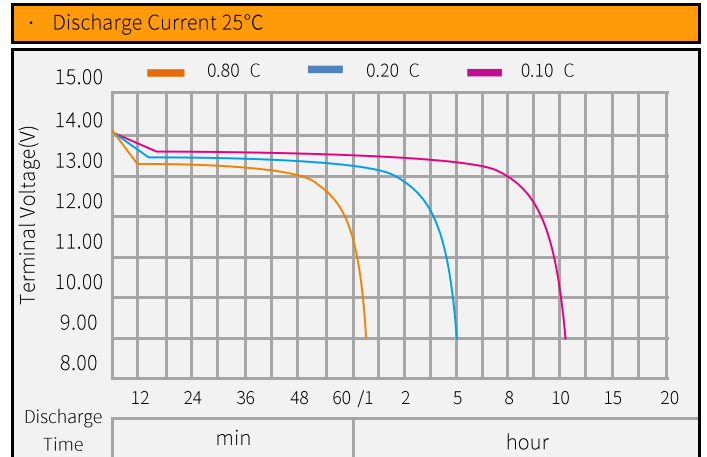

**Long-term Storage**

After the battery is charged, it should be used as soon as possible to avoid loss of usable capacity due to self-discharge.

If storage is required, the battery needs to be stored in a low SOC state. The recommended storage conditions are: 20%~40%SOC, 0°C~35°C, relative humidity ≤60%.

**Constant Current Discharge Characteristics (A, 25°C)**

Time(h)	1.25	2.50	5.00	6.25	10.00	12.50	18.75	25.00
Current (A)	120.00	60.00	30.00	24.00	15.00	12.00	8.00	6.00

**Constant Power Discharge Characteristics (Watt, 25°C)**

Time(h)	1.25	2.50	5.00	6.25	10.00	12.50	18.75	25.00
Watt (W)	1536.00	768.00	384.00	307.20	192.00	153.60	102.40	76.80

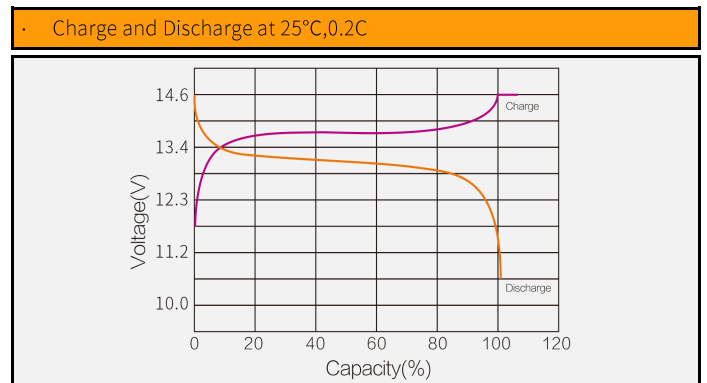

**Capacity Factors With Different Temperature**

Discharge	-20	-10	0	10	20	25	30	40	50	55	60
	≥55	≥70	≥90	≥95	≥100	≥100	≥100	≥98	≥97	≥95	≥93

- Matters needing attention**
- ★ The above parameters are for reference only. The accurate parameters shall be based on the actual production order.
  - ★ During usage, it is strictly prohibited to reverse the positive and negative terminals of the battery.
  - ★ Please use a special charger for lithium-ion batteries when charging.
  - ★ If series or parallel connection is required, please consult the agent or manufacturer.