

Thank you for purchasing our portable LED spotlight. Please read this manual carefully and heed the safety warnings and instructions before installing, using or repairing the unit. Doing so will ensure not only the protection of persons, but also the longevity of the equipment.

TECHNICAL PARAMETERS

Luminous flux	5000lm*
Power	50W
Chromaticity	4000K
Light source	100x LED SMD2835
Batteries	Li-Ion (12000mAh, 3.7V)
Battery life	min. 2h/max. 10h
Battery charging time	about 10h
LED lifetime	20.000 hours
Coverage	IP54

* maximum luminous flux is achieved at full charge

DESCRIPTION OF EQUIPMENT

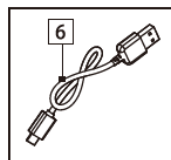
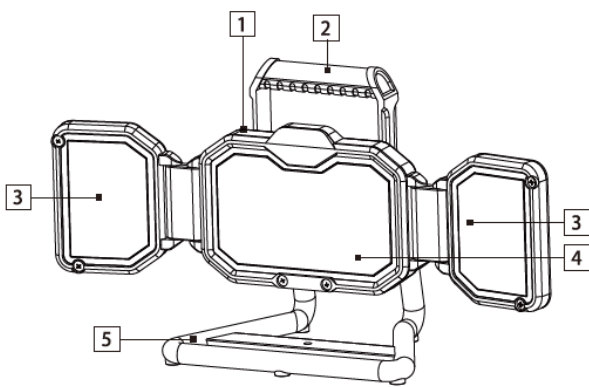

1. Spotlight
2. Handle
3. LED panel
4. LED panel
5. Stand
6. USB-C charging cable
7. Wing nut for fixing the tilt
8. Charging indicator
9. Battery status button
10. USB-C socket cover
11. ON/OFF button
12. USB-C charging socket

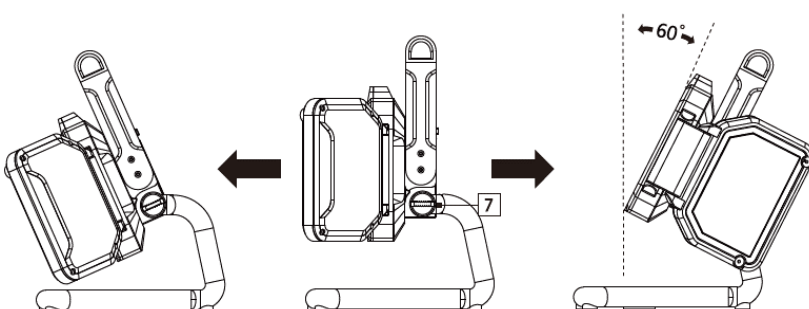
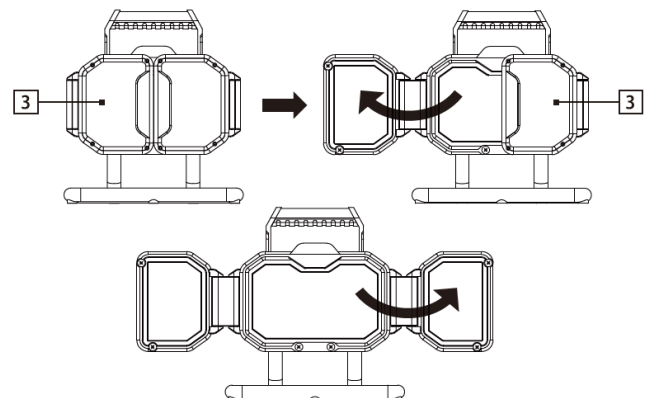
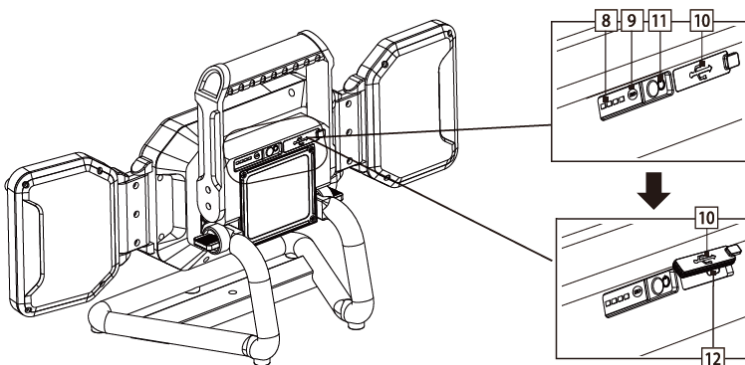

SAFETY NOTICE

- Fully charge the batteries before starting the device for the first time.
- The device is not intended for children.
- If the device is damaged, do not continue to use it.
- Neither the manufacturer nor the distributor shall be liable for any damage caused by improper use of the product.
- Do not repair or modify the equipment, all repairs must only be carried out by the manufacturer's service centre.
- Do not open the cover or otherwise interfere with the construction of the product.
- Keep the device away from: open flames, hot surfaces and flammable materials.
- Place the device at least 0.1m from the object to be illuminated.
- Do not cover/uncover the product while charging, as this creates a risk of overheating.
- Keep the batteries out of the reach of children.
- The battery is not replaceable, in the event of a failure the entire device must be disposed of at a designated location.

POSITIONING OF THE REFLECTOR

You can adjust the position of the device vertically and horizontally.

1. Using the handle (2), place the product on a flat and stable surface.
2. Fold out LED panels (3)
3. When the desired position is reached, tighten the screws to secure the pivot.

Tighten the pivot screws when the adjustment is complete.

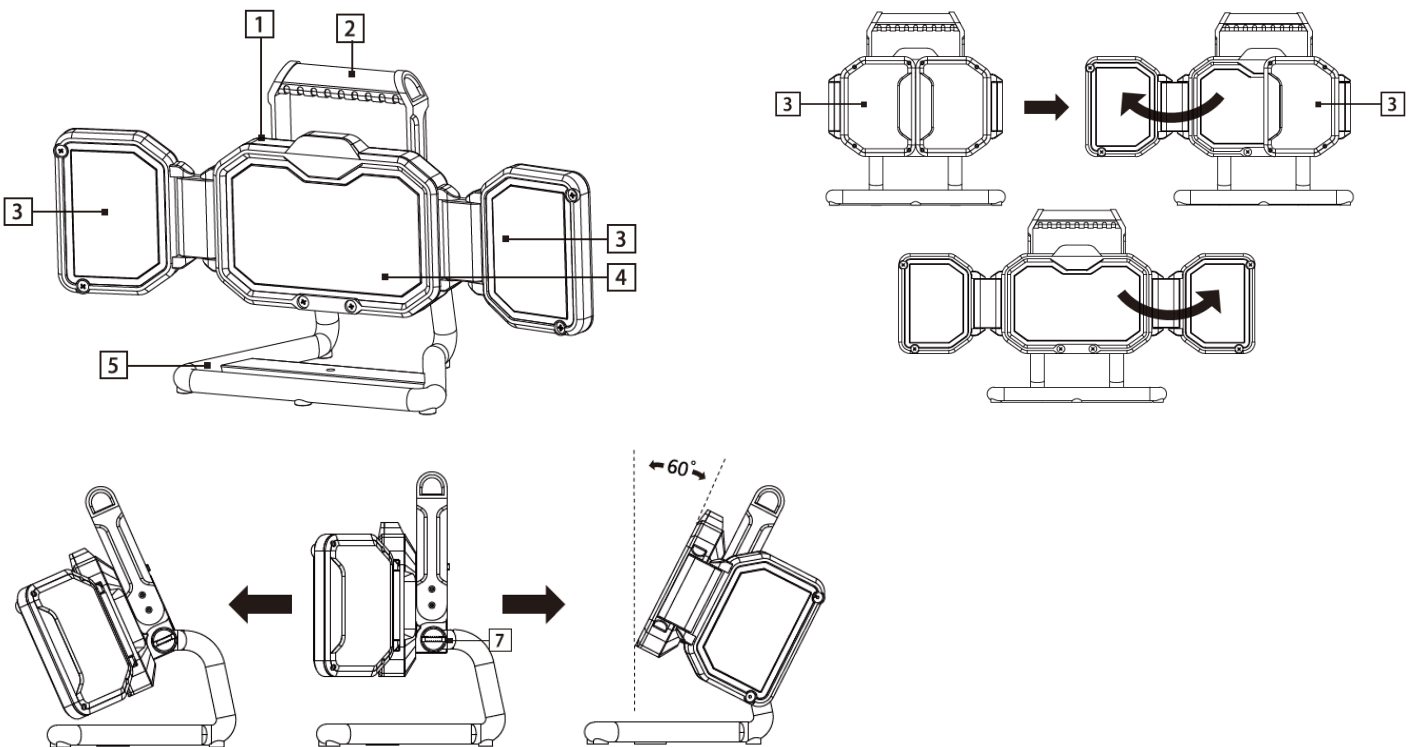

OPERATION OF EQUIPMENT

The device can be operated in different modes. These can be selected by repeatedly pressing the ON/OFF button (11).

1. Press: 100% illumination | 2. Press: 50% illumination | 3. Press: 20% illumination | 4. Off.

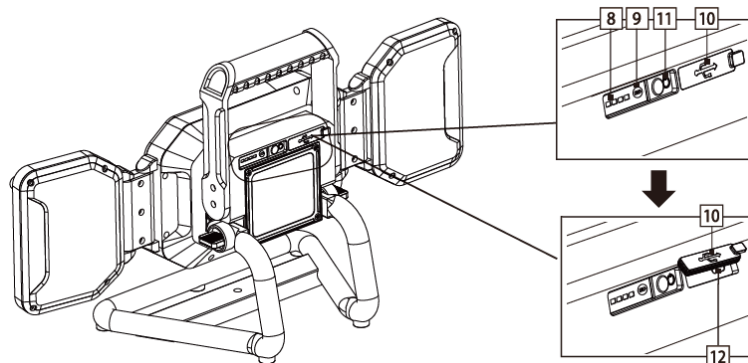

Charging:

Open the cover (10) of the USB-C charging socket and connect the supplied charging cable to the socket (12). Connect the charging cable to a 5V, max. 2A AC adapter (not included) and plug it into a power outlet.

(It is not possible to switch on the reflector while it is charging. Always charge in a dry place.)

When charging, all the indicator lights (8) start flashing. The battery is fully charged when all the indicator lights are on continuously.

NOTE:
After charging is complete, be sure to reattach the USB input cover (10) to protect the reflector from moisture and to ensure protection against splashing water.

Off/on:
Press the ON/OFF button (11) to switch the device on/off.

Maintenance and storage:
Do not use chemicals for cleaning. Use a dry, lint-free cloth. Clean only when the product is switched off and disconnected.

When not in use, store the device in a dry place inside its packaging.

To maintain the capacity of the rechargeable battery, the device needs to be charged for two hours every 4 months.

The light source of this luminaire is non-replaceable, at the end of its service life the entire luminaire must be replaced and disposed of in a designated place. This product contains a light source that for design reasons cannot be removed for verification and therefore the entire product is considered a light source.

