



■ Features

- Universal AC input / Full range
- Protections: Short circuit / Overload / Over voltage
- Battery low protection / Battery reverse polarity protection by fuse
- Can be installed on DIN rail TS-35/7.5 or 15
- Alarm signal for AC OK and Battery low (via TTL open collector, optional via relay)
- Cooling by free air convection
- Pass LPS
- LED indicator for power on
- 100% full load burn-in test
- 3 years warranty

■ Applications

- Security system
- Emergency lighting system
- Alarm system
- DC UPS system
- Central monitoring system
- Access systems

■ Description

DRC-40 is a 40W AC/DC DIN rail type security power supply series. In addition to the primary output, there is a charger output with a smaller rated current, enabling the backup power supply application the security access systems require. DRC-40 accepts the universal input between 90VAC and 264VAC, and supplies 13.8VDC and 27.6VDC at output, respectively. With the efficiency up to 87%, it can operate with air convection cooling under -30°C through 70°C. In addition to the key protection features such as overload protection, over voltage protection, battery low cut off, and battery reverse polarity protection (by fuse), the alarm signal for AC OK and battery low signaling is provided, via TTL open collector output for the standard model (via relay contact output as the optional model), to facilitate the system design.

■ Model Encoding

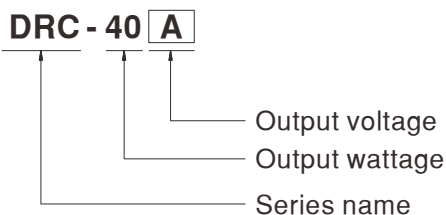

**SPECIFICATION**

MODEL		DRC-40A		DRC-40B	
OUTPUT	OUTPUT NUMBER	CH1	CH2	CH1	CH2
	DC VOLTAGE	13.8V	13.8V	27.6V	27.6V
	RATED CURRENT	1.9A	1A	0.95A	0.5A
	CURRENT RANGE	0 ~ 2.9A	-----	0 ~ 1.45A	-----
	RATED POWER	40.02W		40.02W	
	RIPPLE & NOISE (max.) Note.2	120mVp-p	-----	200mVp-p	-----
	VOLTAGE ADJ. RANGE	CH1:12 ~ 15V		CH1:24 ~ 30V	
	VOLTAGE TOLERANCE Note.3	± 1.0%	-----	± 1.0%	-----
	LINE REGULATION	± 0.5%	-----	± 0.5%	-----
	LOAD REGULATION	± 0.5%	-----	± 0.5%	-----
	SETUP, RISE TIME Note.4	400ms, 50ms/230VAC	800ms, 50ms/115VAC at full load		
	HOLD UP TIME (Typ.)	50ms/230VAC	10ms/115VAC at full load		
INPUT	VOLTAGE RANGE	90 ~ 264VAC	127 ~ 370VDC	[DC input operation possible by connecting AC/L(+), AC/N(-)]	
	FREQUENCY RANGE	47 ~ 63Hz			
	EFFICIENCY (Typ.)	86%		87%	
	AC CURRENT (Typ.)	0.8A/115VAC	0.6A/230VAC		
	INRUSH CURRENT (Typ.)	COLD START 30A/115VAC		60A/230VAC	
PROTECTION	OVERLOAD	105 ~ 150% rated output power Protection type : Hiccup mode, recovers automatically after fault condition is removed			
	OVER VOLTAGE	CH1:14.49 ~ 18.63V		CH1:28.98 ~ 37.26V Protection type : Shut down o/p voltage, re-power on to recover	
	BATTERY CUT OFF	10 ± 0.5V		20 ± 1V	
FUNCTION	AC OK	Open collector output, CONTACT : AC OK ; CUT OFF : AC Fail ; max. rating : 50V/30mA			
	BATTERY LOW	Open collector output, CUT OFF : Battery ; CONTACT : Battery Low ; max. rating : 50V/30mA Battery low voltage : < 11V		Battery low voltage : < 22V	
ENVIRONMENT	WORKING TEMP.	-30 ~ +70°C (Refer to "Derating Curve")			
	WORKING HUMIDITY	20 ~ 90% RH non-condensing			
	STORAGE TEMP., HUMIDITY	-40 ~ +85°C, 10 ~ 95% RH			
	TEMP. COEFFICIENT	± 0.03%/°C (0 ~ 55°C) on CH1 output			
	VIBRATION	10 ~ 500Hz, 2G 10min./1cycle, 60min. each along X, Y, Z axes			
SAFETY & EMC (Note 5)	SAFETY STANDARDS	UL60950-1, TUV EN60950-1 approved			
	WITHSTAND VOLTAGE	I/P-O/P:3KVAC I/P-FG:2KVAC O/P-FG:0.5KVAC			
	ISOLATION RESISTANCE	I/P-O/P, I/P-FG, O/P-FG:100M Ohms / 500VDC / 25°C / 70% RH			
	EMC EMISSION	Compliance to EN55022 (CISPR22) Class B, EN61000-3-2,-3			
	EMC IMMUNITY	Compliance to EN61000-4-2,3,4,5,6,8,11, EN55024, EN61204-3, light industry level, criteria A			
OTHERS	MTBF	536.6K hrs min. MIL-HDBK-217F (25°C)			
	DIMENSION	40*90*100mm (W*H*D)			
	PACKING	0.3Kg; 42pcs/13.6Kg/0.82CUFT			
NOTE	<p>1. All parameters NOT specially mentioned are measured at 230VAC input, rated load and 25°C of ambient temperature.</p> <p>2. Ripple & noise are measured at 20MHz of bandwidth by using a 12" twisted pair-wire terminated with a 0.1uf & 47uf parallel capacitor.</p> <p>3. Tolerance : includes set up tolerance, line regulation and load regulation.</p> <p>4. Length of set up time is measured at cold first start. Turning ON/OFF the power supply may lead to increase of the set up time.</p> <p>5. The power supply is considered a component which will be installed into a final equipment. The final equipment must be re-confirmed that it still meets EMC directives. For guidance on how to perform these EMC tests, please refer to "EMI testing of component power supplies." (as available on http://www.meanwell.com)</p> <p>6. Installation clearances : 40mm on top, 20mm on the bottom, 5mm on the left and right side are recommended when loaded permanently with full power. In case the adjacent device is a heat source, 15mm clearance is recommended.</p>				

■ Block Diagram

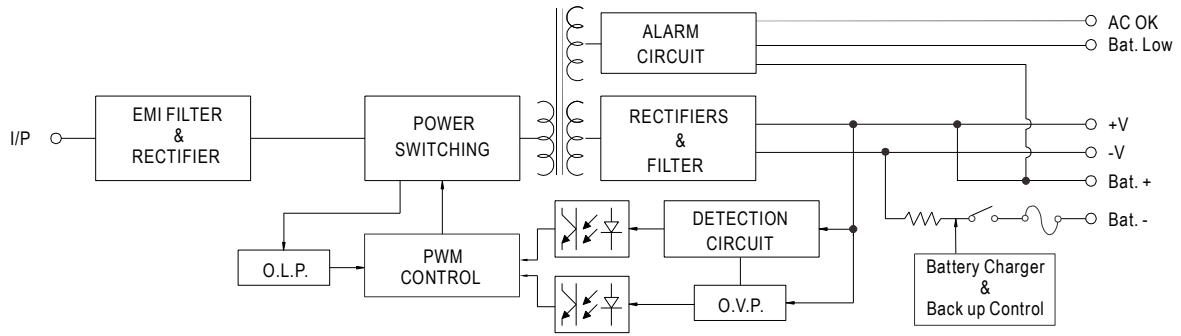

■ Derating Curve

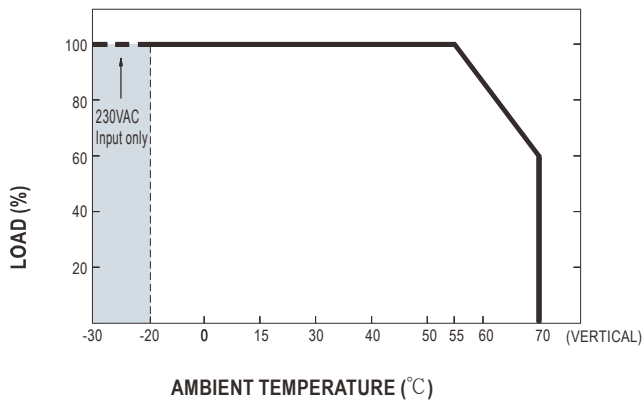

■ Static Characteristics

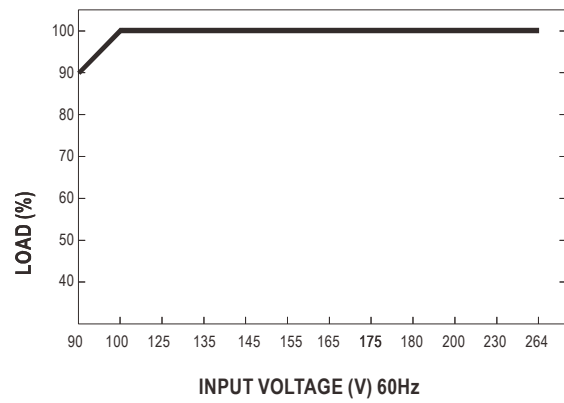

Suggested Application

1.Backup connection for AC interruption

(1) Please refer to Fig 1.1 for suggested connection.

The power supply charges the battery and provides energy to the load at the same time when AC mains is OK.
The battery starts to supply power to the load when AC mains fails.

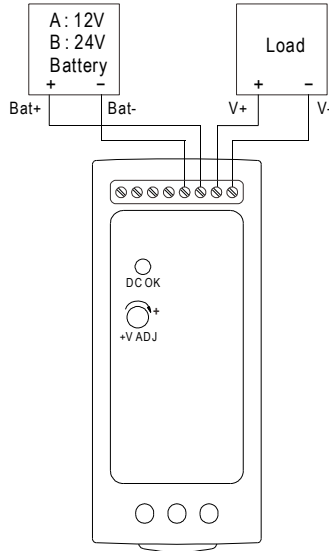

Fig 1.1 Suggested system connection

2.Alarm signal for AC OK and battery low

- (1) Alarm signal is sent out through "AC OK " & " Battery Low " pins. (TTL open collector output is provided for standard model, and relay contact output is provided as optional model.)
- (2) An external voltage source is required for this function. The maximum applied voltage is 50V and the maximum sink current is 30mA. Please refer to Fig 2.2.
- (3) Table 2.1 explains the alarm function built in the power supply

Function	Description	Output of alarm
AC OK	The signal is "Low" when the power supply turns ON.	Low (0.3V max. at 30mA)
	The signal turns to be "High" when the power supply turns OFF.	High or open (External applied voltage 50V max.)
Battery Low	The signal is "Low" when the voltage of battery is under A:11V, B:22V.	Low (0.3V max. at 30mA)
	The signal is "High" when the voltage of battery is above A:11V, B:22V.	High or open (External applied voltage 50V max.)

Table 2.1 Explanation of alarm signal

AC OK (Battery low)

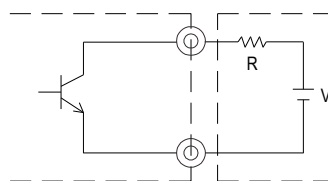

Pin6(Pin8) Short with output -V External voltage and R
(The max. Sink is 30mA and 50V)

Fig 2.2 Internal circuit of AC OK (Battery Low), via TTL open collector

Mechanical Specification

Case No.962A Unit:mm

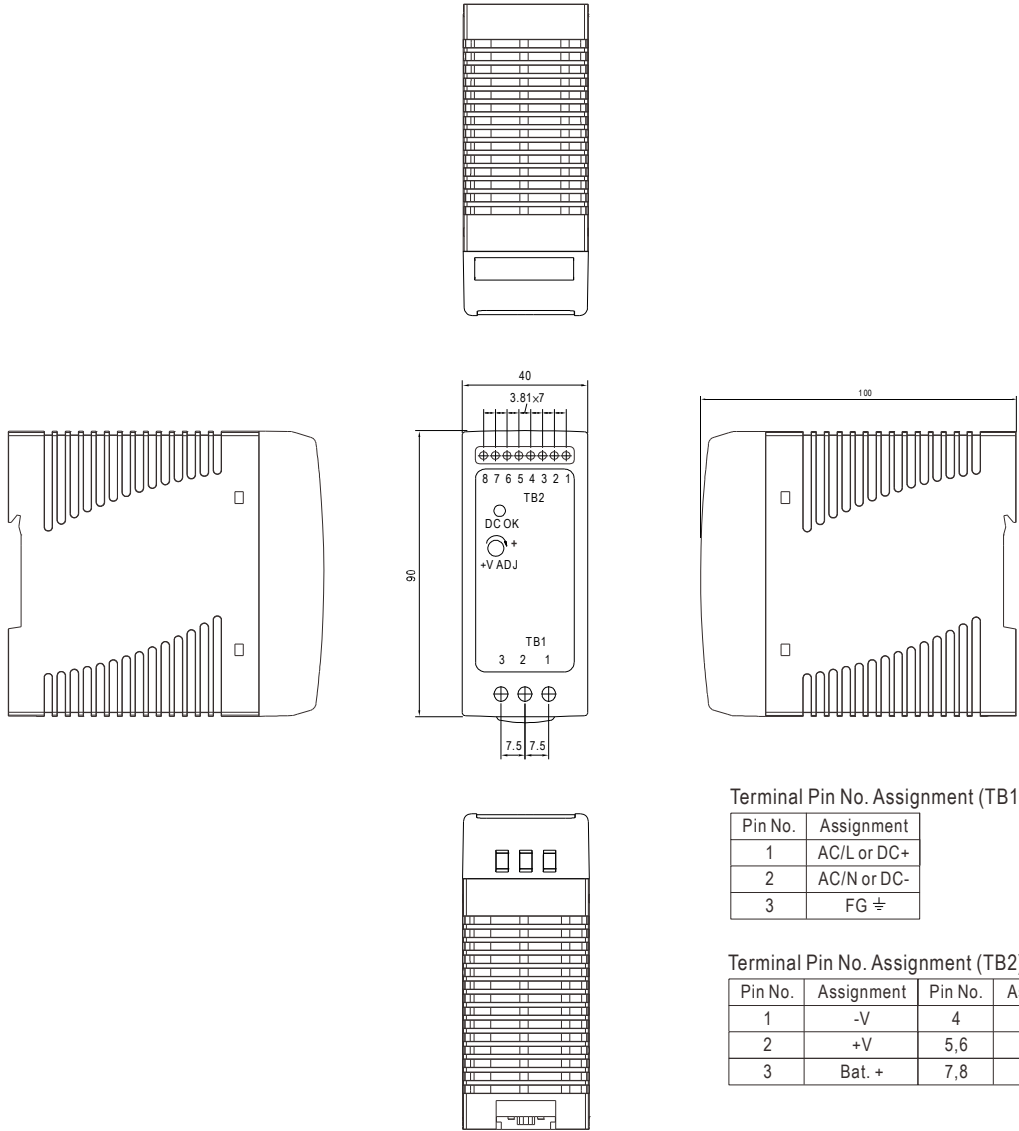

Terminal Pin No. Assignment (TB1):

Pin No.	Assignment
1	AC/L or DC+
2	AC/N or DC-
3	FG \perp

Terminal Pin No. Assignment (TB2):

Pin No.	Assignment	Pin No.	Assignment
1	-V	4	Bat. -
2	+V	5,6	AC OK
3	Bat. +	7,8	Bat. Low

Installation Instruction

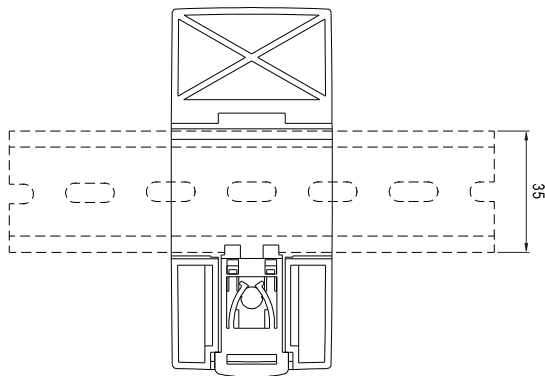

Back View

This series fits DIN rail TS35/7.5 or TS35/15.
(This diagram is for reference. The rail is not included with unit.)